

CASE STUDY



Six Sigma DMAIC methodologies steer one of the industry's global suppliers of bauxite, alumina and aluminum to

Doerfer's AGV Pot Line Systems for ore bucket management using Omni-directional Wheelift technology

Challenge: To eliminate unsafe conditions, high traffic, equipment failures, high maintenance, and unpredictability. Any replacement process requires high load capacity, close positioning, repeatability, and a high degree of maneuverability for operating in narrow aisles with other vehicle and pedestrian traffic.

Solution: Provide fully automatic system with two dual position 60 ton capacity Wheelift AGVs with inertial guidance navigation. Each is capable of overlapping Pot room coverage providing 100% redundancy.

Benefits:

- Area safety
- Process control
- Pot Room delivery redundancy
- Greatly reduced traffic via dual load deck

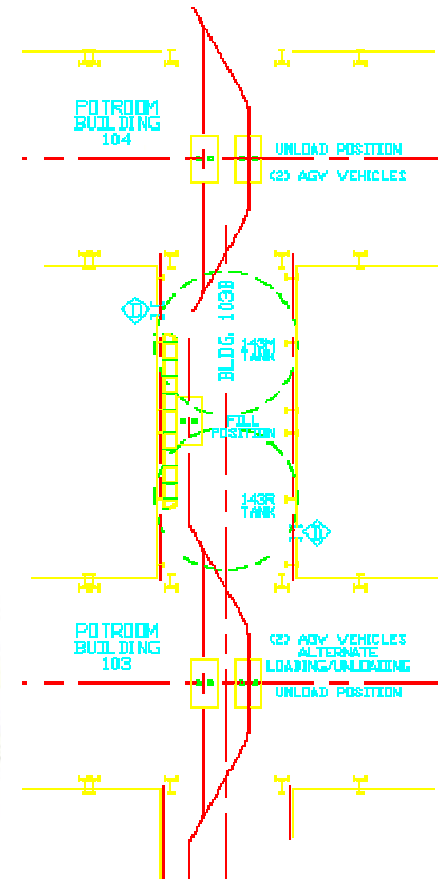
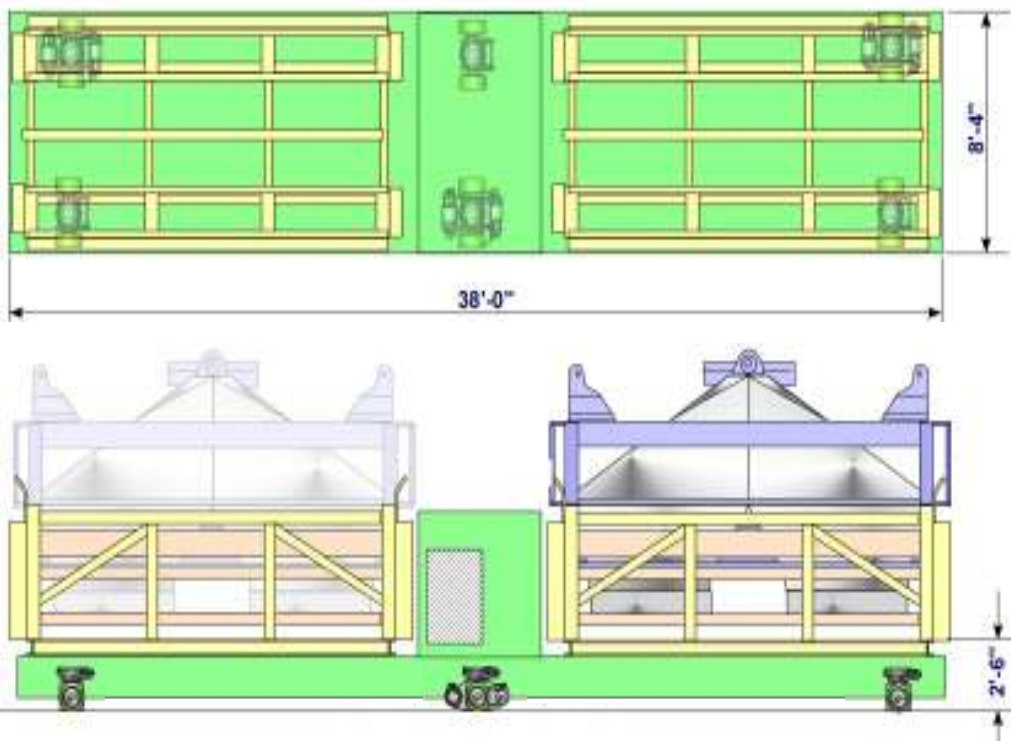

Crab steering, bi-directional movement, wireless navigation, 360-degree laser protection, and dual load decks are the key attributes of Doerfer's AGV Pot Line System for ore bucket management. It offers one-of-a-kind solution no other technology set can duplicate.

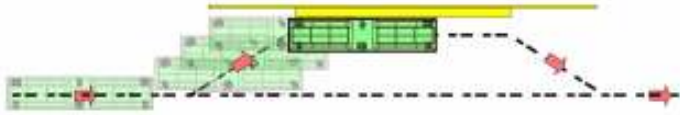

Pot lines are a dangerous area subject to air-born alumina, floor buildup, floor debris, and hot depleted anodes along with green anode delivery and other traffic.

Early ore bucket systems used a variety of explosive LP powered tugs towing single position trailers. This type of process requires large turning radii, sweeping moves, and continual load jogging for crane hookup alignment and filler tube insertion. A primary safety issue adding substantial risk with every move is that the tug operator can not see around the ore bucket. Operator mobilization every time a fill or drop-off is called for drives productivity down. Later systems used single load position AGVs; however 50% of the moves are dead-headed creating undue traffic risk along with added capital and life cycle expenses.



Doerfer's Wheelift AGVs have six on-center rotation axle assemblies making a 38' long dual load deck practical and cost efficient. With their 3-point fluid equalizing suspension, the axles have

interconnecting fluid lines that divide them into load sharing groups to assure that every wheel carries only its specific share of the load, regardless of ore bucket load condition, obstacles, slopes, and irregularities in the floor surfaces. Floor loading is dispersed with ground pressure loads distributed over a wide footprint.

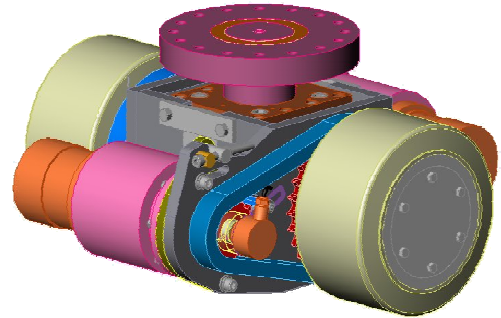

The Wheelift module provides high capacity along with a degree of flexibility not obtainable through other technologies. Worldwide niche markets drive manufacturing flexibility for product customization and configurable work processes. Wheelift Transporters and AGVs facilitate this requirement.

Manufactured in Iowa, **Wheelift** Transporters and AGVs are custom developed to each application including close positioning die loading, roll transfers, assembly, and general material handling. Load deck and fixturing is built to suit with load capacities to 500+ tons and deck heights as low as 18". Power options include LP gas, diesel, battery, or on-board generator. Electric or hydraulic drives are standard. For more information on our Wheelift Transporter and inertial/wire guidance AGV systems, please visit us at www.wheelift.com

Headquartered in Iowa, **Doerfer** develops application specific, custom manufacturing systems and machinery - many which revolutionize the way our customers manufacture, assemble, move, package, and test their products. We thrive on your toughest process challenges for manufacturing. For more information on our capabilities, please visit us at www.doerfer.com